

Instructions



A6303 & A6303XL 100 Amp AC/DC Current Probe 070-3906-04

Warning

The servicing instructions are for use by qualified personnel only. To avoid personal injury, do not perform any servicing unless you are qualified to do so. Refer to all safety summaries prior to performing service.

www.tektronix.com

Copyright © Tektronix, Inc. All rights reserved.

Tektronix products are covered by U.S. and foreign patents, issued and pending. Information in this publication supercedes that in all previously published material. Specifications and price change privileges reserved.

Tektronix, Inc., P.O. Box 500, Beaverton, OR 97077

TEKTRONIX and TEK are registered trademarks of Tektronix, Inc.

WARRANTY

Tektronix warrants that the products that it manufactures and sells will be free from defects in materials and workmanship for a period of one (1) year from the date of shipment. If a product proves defective during this warranty period, Tektronix, at its option, either will repair the defective product without charge for parts and labor, or will provide a replacement in exchange for the defective product.

In order to obtain service under this warranty, Customer must notify Tektronix of the defect before the expiration of the warranty period and make suitable arrangements for the performance of service. Customer shall be responsible for packaging and shipping the defective product to the service center designated by Tektronix, with shipping charges prepaid. Tektronix shall pay for the return of the product to Customer if the shipment is to a location within the country in which the Tektronix service center is located. Customer shall be responsible for paying all shipping charges, duties, taxes, and any other charges for products returned to any other locations.

This warranty shall not apply to any defect, failure or damage caused by improper use or improper or inadequate maintenance and care. Tektronix shall not be obligated to furnish service under this warranty a) to repair damage resulting from attempts by personnel other than Tektronix representatives to install, repair or service the product; b) to repair damage resulting from improper use or connection to incompatible equipment; c) to repair any damage or malfunction caused by the use of non-Tektronix supplies; or d) to service a product that has been modified or integrated with other products when the effect of such modification or integration increases the time or difficulty of servicing the product.

THIS WARRANTY IS GIVEN BY TEKTRONIX IN LIEU OF ANY OTHER WARRANTIES, EXPRESS OR IMPLIED. TEKTRONIX AND ITS VENDORS DISCLAIM ANY IMPLIED WARRANTIES OF MERCHANTABILITY OR FITNESS FOR A PARTICULAR PURPOSE. TEKTRONIX' RESPONSIBILITY TO REPAIR OR REPLACE DEFECTIVE PRODUCTS IS THE SOLE AND EXCLUSIVE REMEDY PROVIDED TO THE CUSTOMER FOR BREACH OF THIS WARRANTY. TEKTRONIX AND ITS VENDORS WILL NOT BE LIABLE FOR ANY INDIRECT, SPECIAL, INCIDENTAL, OR CONSEQUENTIAL DAMAGES IRRESPECTIVE OF WHETHER TEKTRONIX OR THE VENDOR HAS ADVANCE NOTICE OF THE POSSIBILITY OF SUCH DAMAGES.

Contacting Tektronix

Phone	1-800-833-9200*
Address	Tektronix, Inc. Department or name (if known) 14200 SW Karl Braun Drive P.O. Box 500 Beaverton, OR 97077 USA
Web site	www.tektronix.com
Sales support	1-800-833-9200, select option 1*
Service support	1-800-833-9200, select option 2*
Technical support	Email: techsupport@tektronix.com 1-800-833-9200, select option 3* 1-503-627-2400 6:00 a.m. – 5:00 p.m. Pacific time

* This phone number is toll free in North America. After office hours, please leave a voice mail message.
Outside North America, contact a Tektronix sales office or distributor; see the Tektronix web site for a list of offices.

Table of Contents

General Safety Summary	ii
Service Safety Summary	iv
Getting Started	1
Probe Installation	1
Operating the Current Probe Slide	2
Degaussing and Autobalancing the Current Probe	3
Why Degauss the Current Probe?	3
Maximum Current Limits	4
Specifications	6
Maintenance	11
Cleaning	11
Disassembly Instructions	11
Obtaining Replacement Parts	13
Preparation for Shipment	14
Replaceable Parts List	15
Parts Ordering Information	15
Using the Replaceable Parts List	15

General Safety Summary

Review the following safety precautions to avoid injury and prevent damage to this product or any products connected to it. To avoid potential hazards, use this product only as specified.

Only qualified personnel should perform service procedures.

To Avoid Fire or Personal Injury

Connect and Disconnect Properly. Do not connect or disconnect probes or test leads while they are connected to a voltage source.

Ground the Product. This product is indirectly grounded through the grounding conductor of the mainframe power cord. To avoid electric shock, the grounding conductor must be connected to earth ground. Before making connections to the input or output terminals of the product, ensure that the product is properly grounded.

Observe All Terminal Ratings. To avoid fire or shock hazard, observe all ratings and marking on the product. Consult the product manual for further ratings information before making connections to the product.

The common terminal is at ground potential. Do not connect the common terminal to elevated voltages.

Do Not Operate Without Covers. Do not operate this product with covers or panels removed.

Avoid Exposed Circuitry. Do not touch exposed connections and components when power is present.

Do Not Operate With Suspected Failures. If you suspect there is damage to this product, have it inspected by qualified service personnel.

Do Not Operate in Wet/Damp Conditions.

Do Not Operate in an Explosive Atmosphere.

Keep Product Surfaces Clean and Dry.

Symbols and Terms

Terms in this Manual. These terms may appear in this manual:



WARNING. Warning statements identify conditions or practices that could result in injury or loss of life.



CAUTION. Caution statements identify conditions or practices that could result in damage to this product or other property.

Terms on the Product. These terms may appear on the product:

DANGER indicates an injury hazard immediately accessible as you read the marking.

WARNING indicates an injury hazard not immediately accessible as you read the marking.

CAUTION indicates a hazard to property including the product.

Symbols on the Product. The following symbols may appear on the product:



WARNING
High Voltage



Protective Ground
(Earth) Terminal



CAUTION
Refer to Manual



Double
Insulated



Service Safety Summary

Only qualified personnel should perform service procedures. Read this *Service Safety Summary* and the *General Safety Summary* before performing any service procedures.

Do Not Service Alone. Do not perform internal service or adjustments of this product unless another person capable of rendering first aid and resuscitation is present.

Getting Started

This section covers the installation and operation of the A6303 & A6303XL current probes.

The A6303 is a DC to 15 MHz current probe designed for use with the AM503 family of current probe amplifiers and the 11A16 plug-in. The A6303 can measure currents to 100 A (DC + peak AC), and up to 500 A peak current (while not exceeding the amp-second rating).

The A6303XL is an extended length cable version of the A6303. It offers the same current ranges as the A6303 with a diminished frequency range of DC to 10 MHz. The A6303XL can only be used with the AM503B and AM5030, and will not be recognized by other current probe amplifiers.

Please refer to the amplifier documentation for verification procedures, adjustments, and additional specifications.

If you need assistance using your probe, please call our Customer Support Center at 1-800-833-9200 and select option 3. If you are outside the United States or Canada, please contact your nearest Tektronix Service Center.

Probe Installation

To connect a current probe to the Amplifier input connector, align the tab of the probe connector with the slot in the Amplifier **INPUT** connector as shown in Figure 1(a). Align the dot on the probe connector with the groove opening of the input connector as shown in Figure 1(b). Push the probe connector in while twisting the barrel clockwise to lock the connector.



CAUTION. Handle current probes with care. Do not drop a probe or subject it to impact, or the core may crack. Do not connect or disconnect a current probe while the probe is clamped around a live conductor or while the Amplifier is powered on, or the probe may suffer electrical damage.

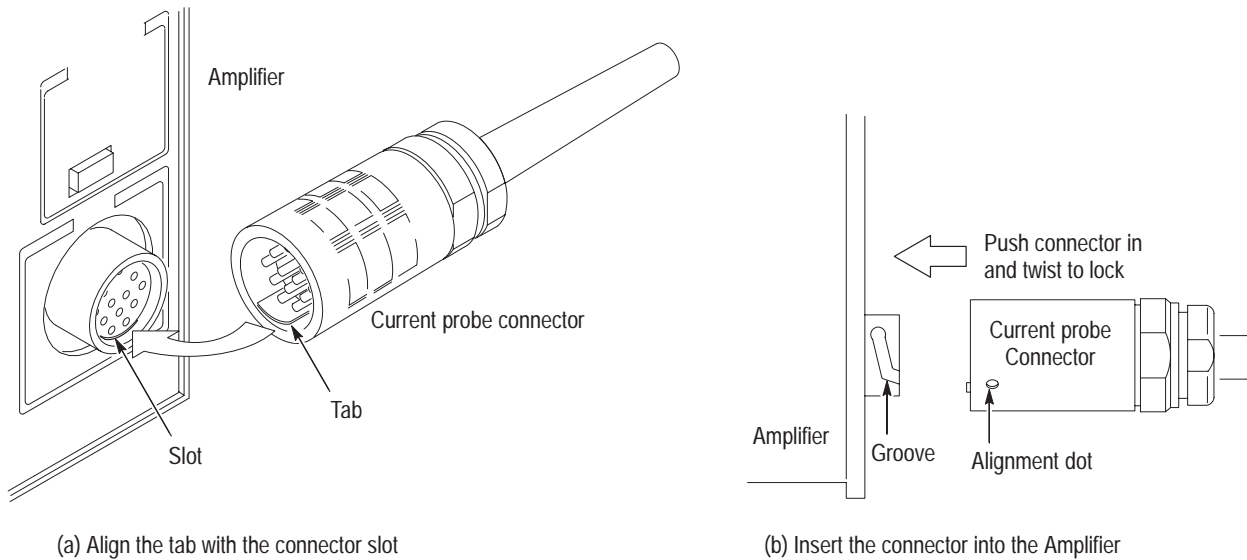

Figure 1: Connecting a current probe to the amplifier

Operating the Current Probe Slide

Each current probe has a slide that opens and closes the probe jaw. This allows you to clamp the probe around a conductor under test. The slide must be locked to accurately measure current or to degauss the probe. If a probe is unlocked, the PROBE OPEN indicator on the Amplifier will light.



WARNING. When the probe slides are open, the exposed ferrite core pieces are not insulated.

To avoid injury or equipment damage, remove power from an uninsulated wire before clamping the current probe around it.

Never disconnect the probe from the Amplifier when the probe is connected to a live conductor.

Allow your hands to contact the probe handle and lock only.

Figure 2 illustrates the slide operation of the probe. To open the probe, press the bottom of the lock button and squeeze the handle until the core is open. To lock the probe, release the squeeze handle and press the top of the lock button.

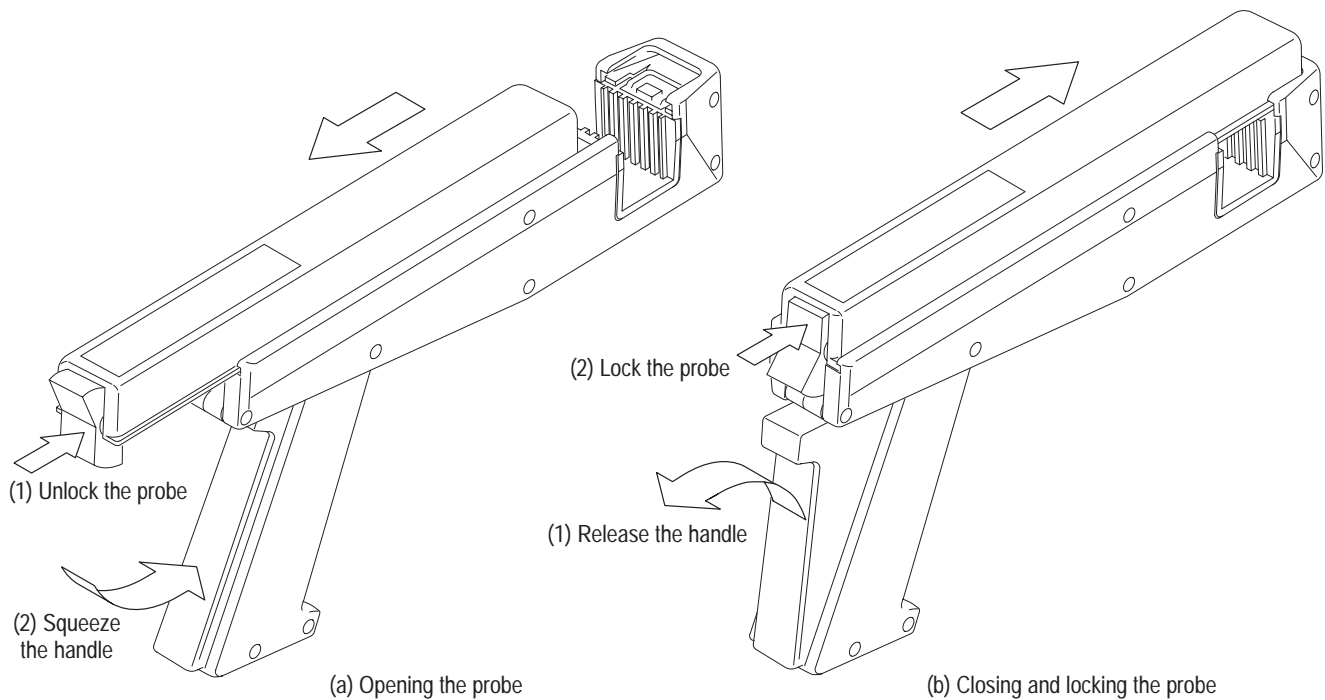

Figure 2: Operating the probe slide

Degaussing and Autobalancing the Current Probe

1. Verify that the current probe is connected to the Amplifier.
2. Remove the current probe from the conductor under test.
3. Lock the probe slide closed as shown in Figure 2(b).
4. Press the Amplifier **PROBE DEGAUSS AUTOBALANCE** button.

NOTE. The degauss procedure will fail if the Amplifier is not properly connected to a 50 Ω termination impedance.

After you have completed the oscilloscope adjustments and the Amplifier degauss/autobalance procedure, your system is ready to measure current.

Why Degauss the Current Probe?

Degaussing the probe removes any residual magnetization from the probe core. Such residual magnetization can induce measurement error. Autobalancing removes unwanted DC offsets in the amplifier circuitry.

Failure to degauss the probe is a leading cause of measurement errors. To maintain measurement accuracy, degauss your probe in each of these cases:

- After turning on the Amplifier and allowing a 20-minute warm-up period.
- Before connecting the probe to a conductor, or changing conductors under test.
- Whenever an overload condition occurs.
- Whenever the probe is subjected to a strong external magnetic field.
- Periodically during normal use.

Maximum Current Limits

Current probes have three maximum current ratings: continuous, pulsed, and Ampere-second product. Exceeding any of these ratings can cause measurement errors or probe heating. See *Specifications* on page 6 for probe current ratings.

- Maximum Continuous Current refers to the maximum current that can be continuously measured at DC or at a specified AC frequency. The maximum continuous current value is derated with frequency; as the frequency increases, the maximum continuous current rating decreases.
- Maximum Pulsed Current refers to the maximum peak value of pulsed current the probe can accurately measure, regardless of how short (within bandwidth limitations) the pulse duration is.
- Ampere-Second Product defines the maximum width of pulsed current that you can measure when the pulse amplitude is between the maximum continuous and maximum pulsed current specifications. The maximum continuous specification itself varies with frequency.

NOTE. Always degauss the probe after measuring a current that exceeds the maximum continuous current, maximum pulsed current, or Ampere-second product rating of the probe. Exceeding these ratings can magnetize the probe and cause measurement errors.

To determine if your measurement exceeds the Ampere-second product, perform either Procedure A or Procedure B:

Procedure A

To determine the maximum allowable pulse width, measure the peak current of the pulse (see Figure 3a). Divide the Ampere-second (or Ampere-microsecond) specification of your probe by the measured peak current of the pulse. The quotient is the maximum allowable pulse width; the pulse width at the 50% point of the measured signal must be less than this value.

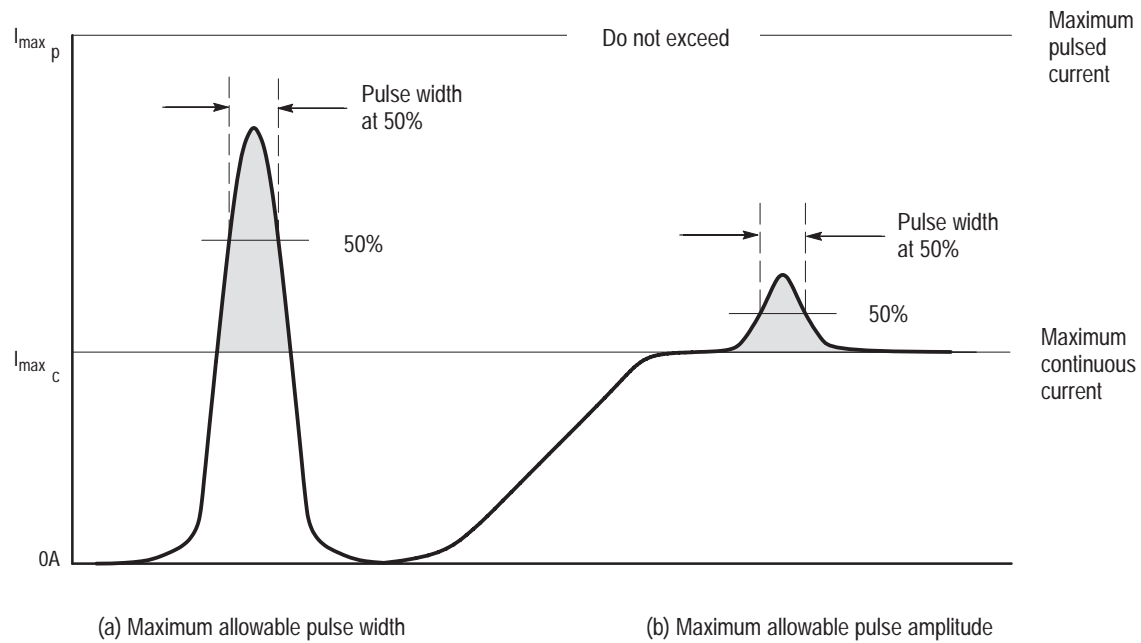

Figure 3: Applying the Amp-second product rule

Procedure B To determine the maximum allowable pulse amplitude, measure the pulse width at the 50% points (see Figure 3b). Divide the Ampere-second (or Ampere-microsecond) specification of your probe by the pulse width. The quotient is the maximum allowable current; the peak amplitude of the measured pulse must be less than this value.

Specifications

Mechanical, electrical, and environmental characteristics unique to the probe are listed in this section. The probe's performance specifications are determined by the amplifier that it is used with. Please refer to the amplifier documentation for probe performance specifications.

Table 1: Electrical Characteristics

Bandwidth (-3 dB)	A6303: DC to 15 MHz A6303XL: DC to 10 MHz
Rise Time (10% to 90%)	A6303: ≤ 23 ns A6303XL: ≤ 35 ns
Frequency Derating	12 A at 10 MHz
Maximum Bare Wire Working Voltage	600 V _{RMS} , CAT II 300 V _{RMS} , CAT III
Maximum Continuous Current	100 A (DC + peak AC)
Maximum Pulsed Current	500 A
Amp · Second Product	1×10^{-2} A · s (10,000 A · μ s)
Insertion Impedance	0.02 Ω at 1 MHz 0.15 Ω at 15 MHz

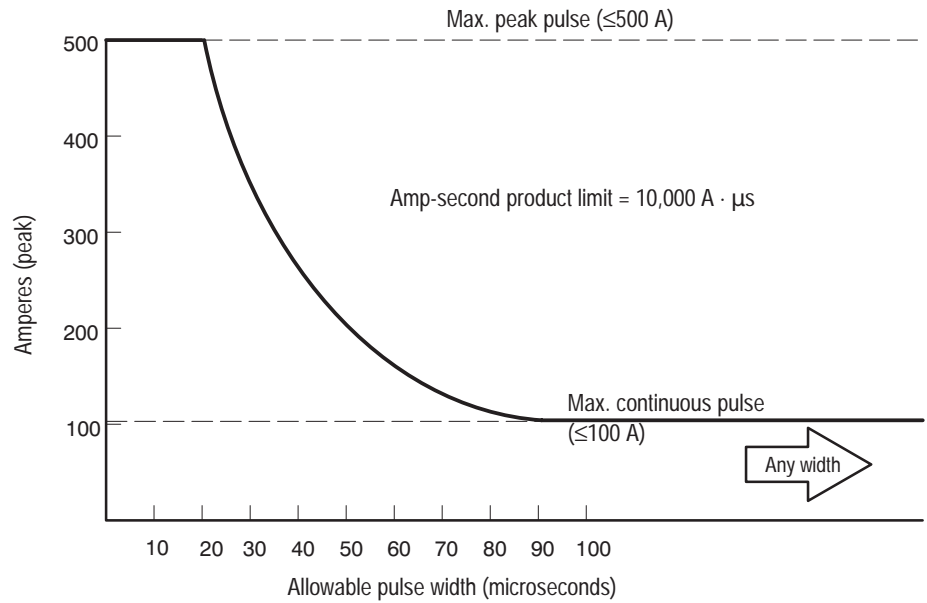

Figure 4: A6303 and A6303XL specified operating area

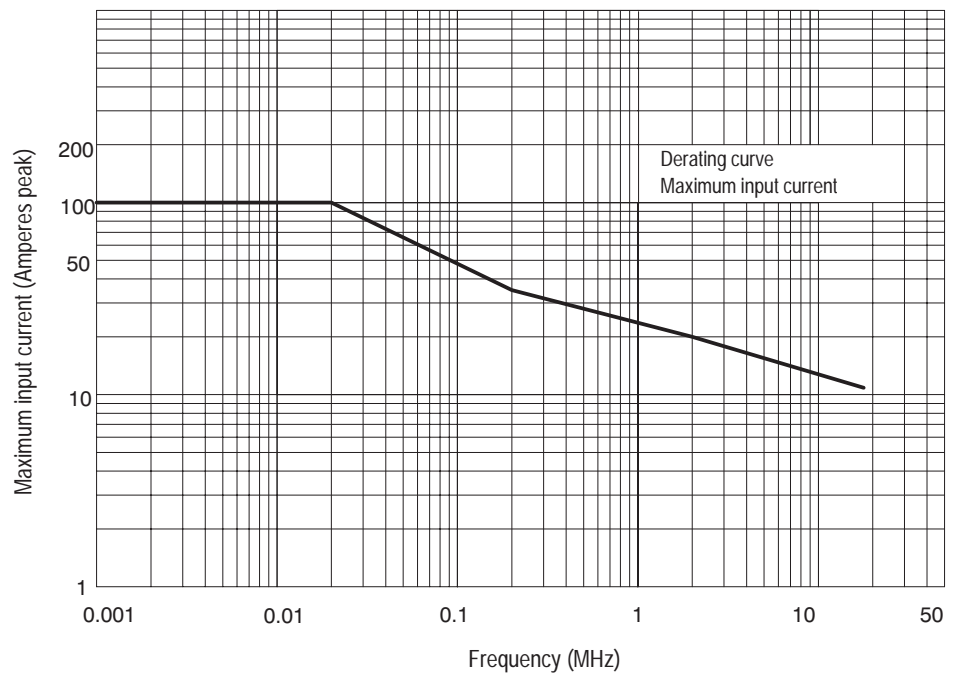

Figure 5: A6303 and A6303XL frequency derating curve

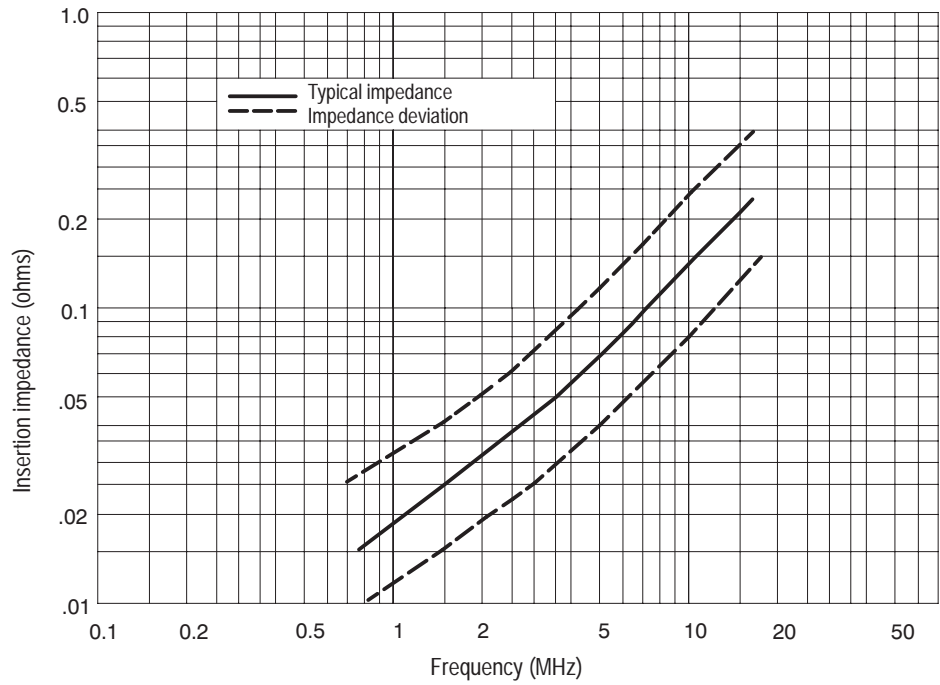

Figure 6: A6303 and A6303XL insertion impedance curve

Table 2: Mechanical Characteristics

Probe Dimensions	Length:	26.8 cm (10.6 inches)
	Width:	4.05 cm (1.6 inches)
	Height:	15.6 cm (6.13 inches)
Cable Length	A6303:	2 m (6.6 feet)
	A6303XL:	8 m (26.25 feet)

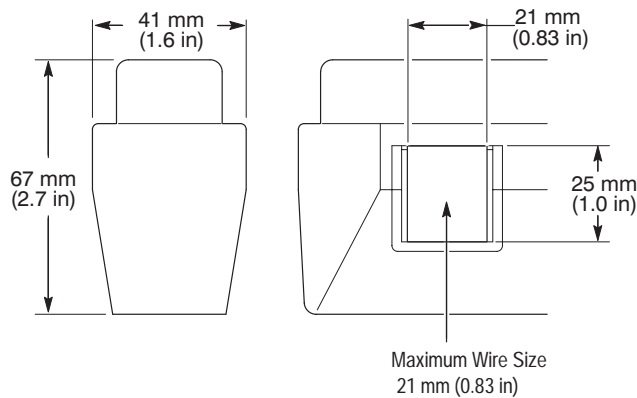

Figure 7: A6303 and A6303XL Probe Jaw Dimensions (Nominal)

Table 3: Environmental Characteristics

Operating Temperature	0°C to 50°C
Storage Temperature	-40°C to 75°C
Humidity	
Nonoperating	30°C to 60°C at 90 to 95% RH
Operating	30°C to 50°C at 90 to 95% RH
Altitude	
Operating	2,000 m (6,416 ft)
Transportation	Qualifies under National Safe Transit Procedure 1A, category II, 36 in. drop.
Mechanical Shock	500 g. Half sine. Three shocks on three of the probe for 1 ms duration. Total of 9 shocks.
Vibration	0.025 in. pk-pk displacement. 10 – 50 Hz in 1min. cycles. Hold 9 min. at any major resonance, or if none, at 55 Hz. Total time, 54 min.
Random Vibration	
Operating	0.31 g _{RMS} , 5 to 500 Hz, 10 minutes on each axis. Tektronix Std. 062-2858-00, Rev. B, Class 3.

Table 4: Certifications and Compliances

<p>EC Declaration of Conformity – Low Voltage</p>	<p>Compliance was demonstrated to the following specification as listed in the Official Journal of the European Communities:</p> <p>Low Voltage Directive 73/23/EEC</p> <p>EN 61010-1:1993 Safety requirements for electrical equipment for measurement, control, and laboratory use</p> <p>EN 61010-2-032:1995 Particular requirements for hand-held current clamps for electrical measurements and test</p>
<p>Approvals</p>	<p>UL3111-1 – Standard for electrical measuring and test equipment</p> <p>CAN/CSA C22.2 No. 1010.1 – Safety requirements for electrical equipment for measurement, control and laboratory use</p> <p>IEC1010-2-032 – Safety requirements for electrical equipment for measurement, control, and laboratory use</p>
<p>Installation Category Descriptions</p>	<p>Terminals on this product may have different installation category designations. The installation categories are:</p> <p>CAT III Distribution-level mains (usually permanently connected). Equipment at this level is typically in a fixed industrial location</p> <p>CAT II Local-level mains (wall sockets). Equipment at this level includes appliances, portable tools, and similar products. Equipment is usually cord-connected</p> <p>CAT I Secondary (signal level) or battery operated circuits of electronic equipment</p>

Maintenance

This section explains how to clean the A6303 & A6303XL current probes and, if necessary, disassemble a probe for maintenance or repair. Also included are instructions for preparing a probe for shipment.

The A6303 & A6303XL current probes should require only routine cleaning. Performance verification and probe adjustment procedures may be found in the AM 503B & AM 5030 Instruction Manual.



WARNING. Probe disassembly should only be performed by qualified service personnel.

Cleaning

To clean the probe body, use a soft cloth dampened in a solution of mild detergent and water. To clean the core, open the jaw and clean the exposed core surfaces with a cotton swap dampened with isopropyl alcohol (isopropanol) or ethyl alcohol (fotocol or ethanol).

Do not lubricate the mating surfaces of the jaws. Any lubricant between the core pieces should be removed with a recommended solvent.

Do not use chemicals containing benzine, benzene, toluene, xylene, acetone, or similar solvents.

Do not use a petroleum based lubricant on the plastic. If the plastic slide assembly requires lubrication, use a silicone based grease sparingly.

Do not immerse the probe in liquids or use abrasive cleaners.

Disassembly Instructions

The following procedures explain how to disassemble the probe body and replace the current transformer.



WARNING. Probe disassembly should only be performed by qualified service personnel.

1. Unlock the probe slide.

2. Place the probe on a flat surface with the screw heads facing up.
3. Using a $\frac{3}{32}$ inch Allen wrench, remove the eight retaining screws from the case.
4. While holding the squeeze handle and slide, lift the top part of the probe body off.
5. Remove the slide.



WARNING. *There is a spring in the squeeze handle that can pop out and cause personal injury unless care is exercised when disassembling the probe.*

6. Lift the cable out of the probe handle and insert a pair of pliers in the handle as shown in Figure 8.

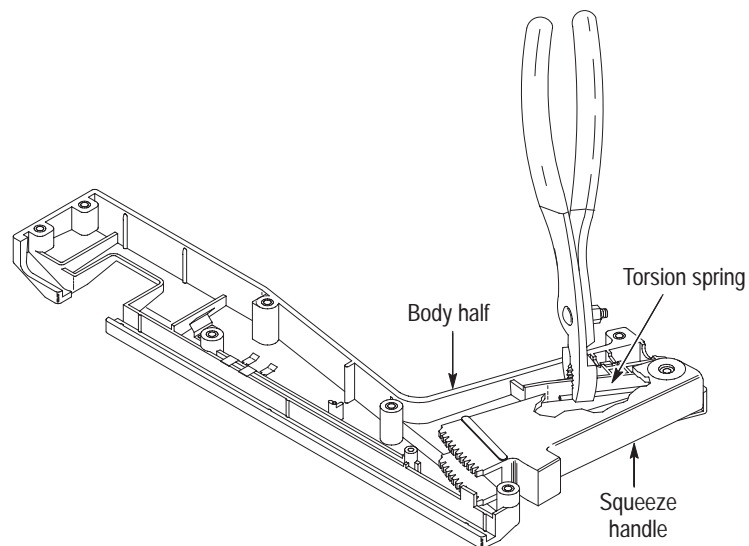

Figure 8: Removing the handle

7. While maintaining a firm grip on the pliers, carefully lift the squeeze handle and gear out of the probe. See Figure 8.
8. To remove the current transformer, lift the assembly out of the probe as shown in Figure 9 and unplug it from the circuit board.

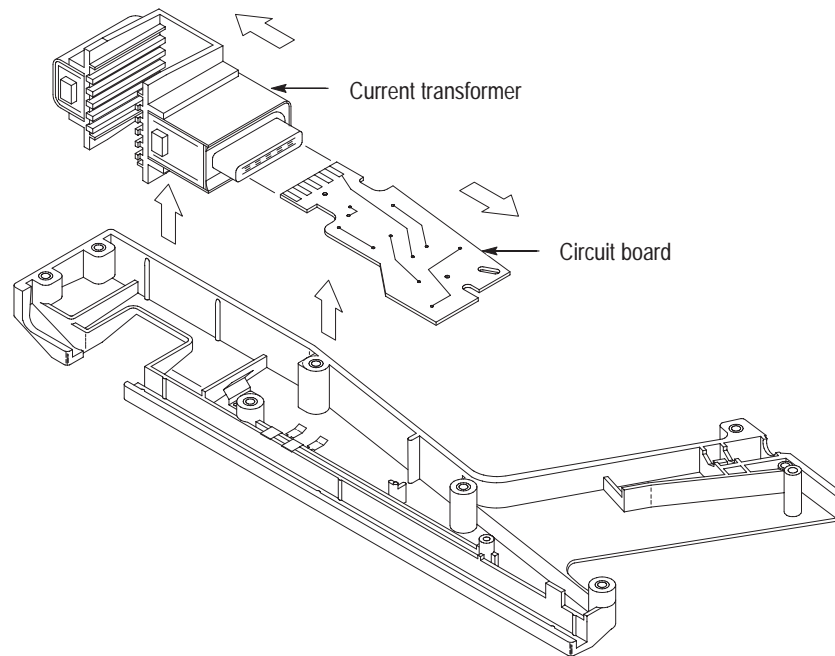

Figure 9: Removing the current transformer

- 9.** To remove the circuit board, unplug the board from the current transformer.
- 10.** Before reassembling the probe, be sure that the gap between the stationary and moveable core pieces is clean. If necessary, use Lubriplate or a similar cleaning agent to clean the pieces. Also, clean the contacts of the slide switch, if necessary.
- 11.** Should the plastic slide assembly require lubrication, sparingly apply silicone-based grease to the parts.
- 12.** Probe reassembly is the reverse of steps 1 through 9. You may need to squeeze the handle slightly to align the gear teeth with the slide rack.

Obtaining Replacement Parts

Replacement parts may be obtained through your local Tektronix field office or representative. Refer to the *Replaceable Parts List* on page 15 for more information.

Preparation for Shipment

If you must ship your Tektronix product, please use the original packaging if possible. If the original packaging is unfit for use or not available, use the following packaging guidelines:

1. Use a corrugated cardboard shipping carton having inside dimensions at least one inch greater than the probe dimensions. The box should have a carton test strength of at least 200 pounds.
2. Put the probe into a plastic bag or wrap to protect it from dampness.
3. Place the probe into the box and stabilize it with light packing material.
4. Seal the carton with shipping tape.

Replaceable Parts List

This section contains a list of the components that are replaceable for the Current Probe. As described below, use these lists to identify and order replacement parts.

Parts Ordering Information

Replacement parts are available from or through your local Tektronix, Inc., service center or representative.

Changes to Tektronix instruments are sometimes made to accommodate improved components as they become available and to give you the benefit of the latest circuit improvements. Therefore, when ordering parts, it is important to include the following information in your order:

- Part number
- Instrument type or model number
- Instrument serial number
- Instrument modification number, if applicable

If a part you order has been replaced with a different or improved part, your local Tektronix service center or representative will contact you concerning any change in the part number.

Using the Replaceable Parts List

The tabular information in the Replaceable Parts List is arranged for quick retrieval. Understanding the structure and features of the list will help you find all the information you need for ordering replacement parts.

Item Names In the Replaceable Parts List, an Item Name is separated from the description by a colon (:). Because of space limitations, an Item Name may sometimes appear as incomplete. For further Item Name identification, U.S. Federal Cataloging Handbook H6-1 can be used where possible.

Abbreviations Abbreviations conform to American National Standards Institute (ANSI) standard Y1.1.

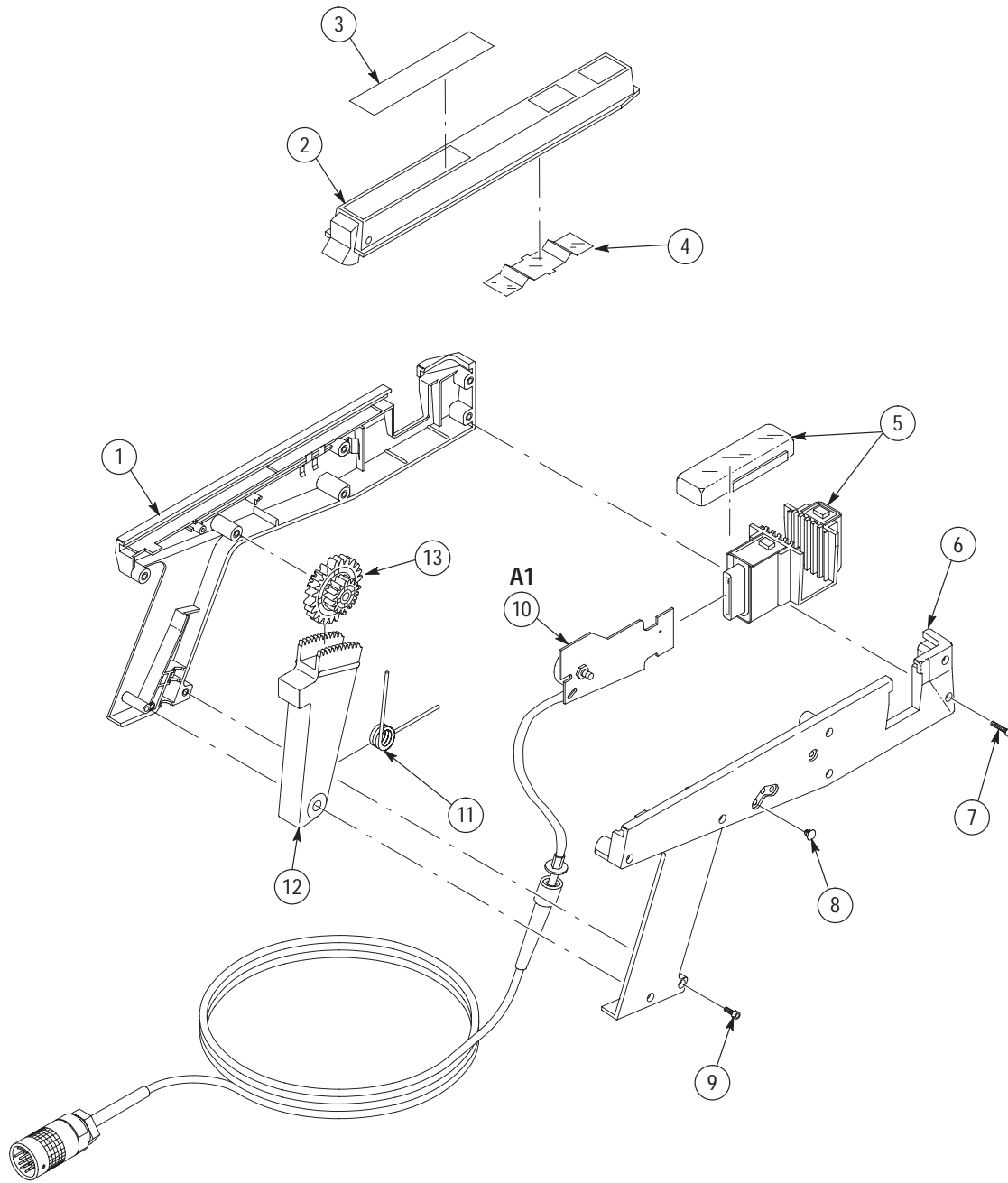

Figure 10: A6303 & A6303XL exploded view

Replaceable Parts List

Fig. & index number	Tektronix part number	Serial no. effective	Serial no. discont'd	Qty	Name & description	Mfr. code	Mfr. part number
10-					PROBE CURRENT:A6303/A6303XL		
-1	204-0713-01			1	BODY HALF,PROBE:LEFT W/CONTACTS P6303	TK1163	ORDER BY DESCRIP
-2	351-0955-00			1	SLIDE ASSEMBLY:WITH WARNING LABEL	80009	351-0955-00
-3	334-4347-01			1	MARKER,IDENT:MKD A6303	07416	334-4347-01
	334-8622-01			1	MARKER,IDENT:MARKED A6303XL	0KB05	334-8622-01
-4	214-2422-00			1	SPRING,FLAT:UPPER CAN	TK1326	214-2422-00
-5	120-1102-00			1	TRANSFORMER,CUR:TOP & BOTTOM	80009	120-1102-00
-6	204-0712-01			1	BODY HALF,PROBE:RIGHT W/CONTACTS P6303	TK1163	ORDER BY DESCRIP
-7	211-0093-00			6	SCREW,CAP:4-40 X 0.75,SCH,STL,CD PL,HEX REC	0KB01	ORDER BY DESCRIP
-8	348-0023-00			4	PLUG,HOLE:U/W0.14 DIA HOLE,WHT PLSTC	02768	207-090201-00-0101
-9	211-0183-00			2	SCREW,CAP:4-40 X 0.5,SCH,STL,CD PL,HEX REC	93907	ORDER BY DESCRIP
-10	174-3247-00		B031152	1	CABLE ASSY:CABLE ASSY W/CKT BD, A6303	80009	174-3247-00
	174-3247-01	B031153		1	CABLE ASSY:W/CKT BD,A6303	80009	174-3247-01
	174-3222-00			1	CABLE ASSEMBLY:WITH CIRCUIT BOARD,A6303XL	80009	174-3222-00
-11	214-2446-00			1	SPR,HLCL,TRSN:0.1 OD X 0.5 L,MUSIC WIRE	8X345	ORDER BY DESCRIP
-12	367-0218-00			1	HANDLE,SQUEEZE:PROBE	TK2565	367-0218-00
-13	401-0352-00			1	GR CLUSTER,SPUR:(2)18 AND (1) 24 T,PLASTIC	TK2565	401-0352-00
					Standard Accessories		
	070-3906-04			1	MANUAL,TECH:INSTRUCTION,A6303,A6303XL,DP	TK2548	070-3906-04
	016-0622-02			1	CASE,CRYG,PROBE:15.5 X 11.0 X 4.5,PLASTIC W/A6303 LABEL	80009	016-0622-02

Manufacturers Cross Index

Mfr. code	Manufacturer	Address	City, state, zip code
02768	ILLINOIS TOOL WORKS INC	195 ALGONQUIN RD	DES PLAINES, IL 60016-6103
07416	NELSON NAME PLATE COMPANY	3191 CASITAS AVENUE	LOS ANGELES, CA 90039-2410
0KB01	STAUFFER SUPPLY CO	810 SE SHERMAN	PORTLAND, OR 97214-4657
0KB05	NORTH STAR NAMEPLATE INC	5750 NE MOORE COURT	HILLSBORO, OR 97124-6474
80009	TEKTRONIX INC	14150 SW KARL BRAUN DR PO BOX 500	BEAVERTON, OR 97077-0001
8X345	NORTHWEST SPRING MFG CO	5858 SW WILLOW LANE	LAKE OSWEGO, OR 97035
93907	CAMCAR DIV OF TEXTRON INC	ATTN: ALICIA SANFORD 516 18TH AVE	ROCKFORD, IL 611045181
TK1163	POLYCAST INC	9898 SW TIGARD ST	TIGARD, OR 97223
TK1326	NORTHWEST FOURSLLIDE INC	18500 SW TETON AVENUE	TUALATIN, OR 97062
TK2548	XEROX CORPORATION	DIV OF XEROX CORPORATION 14181 SW MILLIKAN WAY	BEAVERTON, OR 97005
TK2565	VISION PLASTICS INC	26000 SW PARKWAY CENTER DRIVE	WILSONVILLE, OR 97070